

Frequency Agile IFB Transmitter

- Digital Hybrid Wireless™ technology
- 256 UHF frequencies in 100kHz steps
- Microprocessor controlled operation
- 250 mW power output for long range use
- Pilot tone squelch control
- Multi-use XLR input jack
- Built-in microphone preamp
- DIP switch programmable intercom input
- Tx mute for frequency scrolling
- Multi-function LCD display
- Rugged machined aluminum construction

The Lectrosonics IFBT4 transmitter was designed for use in broadcast, motion picture, theater, and stage applications where extended operating range and high quality audio are essential. The transmitter can be used as a stand-alone device or patched directly into popular intercom systems.

Lectrosonics Digital Hybrid Wireless™ U.S. Patent 7,225,135 systems overcome channel noise in a dramatically new way, digitally encoding the audio in the transmitter and decoding it in the receiver, yet still sending the encoded information via an analog FM wireless link. This proprietary algorithm is not a digital implementation of an analog compandor but a technique that can be accomplished only in the digital domain, even though the inputs and outputs are analog.

Because it uses an analog FM link, Digital Hybrid Wireless™ enjoys all the benefits of conventional FM wireless systems, such as excellent range, efficient use of RF spectrum, and resistance to interference. However, unlike conventional FM systems, it does away with the analog compandor and its artifacts.

256 UHF frequencies in 100kHz steps provide exceptional flexibility in coordinating frequencies in multi-channel wireless systems and avoiding interference from external RF signal sources and noise.



The rear panel provides the audio input and programming DIP switches for intercom and audio input type along with power and antenna input jacks.



Microprocessor control provides user-friendly operation and eliminates transients at turn-on and turn-off. The transmitter output is muted in the TUNE mode to avoid generating interference in other wireless systems while scrolling up and down to change frequencies. In the XMIT mode, the output is turned on and the frequency cannot be changed.

The transmitter delivers 250 mW of output power which, when used with an efficient antenna, provides exceptional operating range with the R1A belt-pack receiver. Indoors, the signal will penetrate various surfaces and reflect from others efficiently to extend operating range and reduce the need for critical antenna positioning.

A supersonic pilot tone signal controls the audio squelch on the R1A receiver to eliminate noise when the transmitter is turned off and it prevents the receiver from locking onto false signals. The pilot tone also eliminates noise in the receiver at turn-on and turn-off.

The LCD display is backlit for use in dimly lit conditions and is also highly visible in direct sunlight.

DIP switch settings on the rear panel provide direct compatibility with RTS and Clear Com intercom systems. A preamp stage is also included in the input stage to allow direct connection to dynamic microphones in “stand-alone” applications. Direct output at studio line level can also be fed directly into the transmitter.

The transmitter housing is rugged, machined aluminum with an electrostatic powder coating and an anodized finish. The unit is powered by 6 to 18 Volts DC via a locking connector. The supplied whip antenna is a detachable, locking 1/4 wavelength flexible, galvanized steel cable that connects to a 50 Ohm BNC connector on the rear panel.

IFBT4 Transmitter Block Diagram

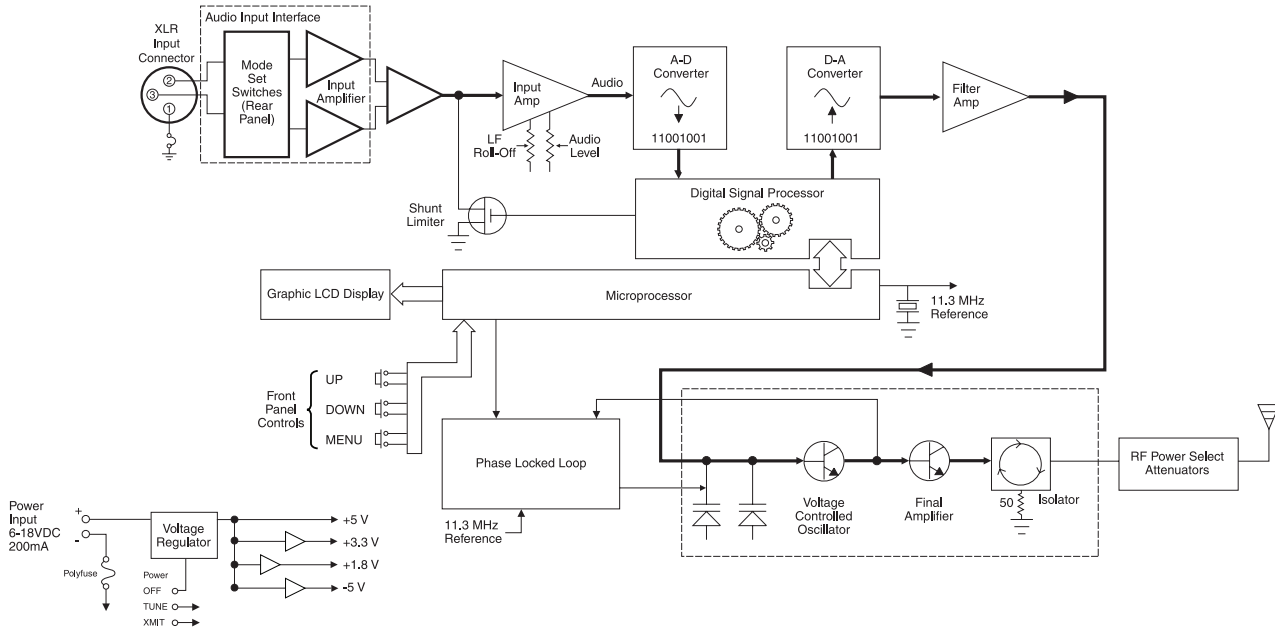

Specifications

Operating Frequencies (MHz):

Block 470	470.100 - 495.600	Block 25	640.000 - 665.500
Block 19	486.400 - 511.900	Block 26	665.600 - 691.100
Block 20	512.000 - 537.500	Block 27	691.200 - 716.700*
Block 21	537.600 - 563.100	Block 28	716.800 - 742.300*
Block 22	563.200 - 588.700	Block 29	742.400 - 767.900*
Block 23	588.800 - 607.900	Block 944	944.100 - 951.900
	614.100 - 614.300		*export only
Block 24	614.400 - 639.900		

Frequencies (Channels per block): 256

Channel Spacing: 100 kHz (0.1 MHz)

RF Power Output: 250 mW

Spurious & Harmonic Suppression: 37 dBc above 1 GHz

Frequency Stability: $\pm 0.01\%$ (10 ppm) @ 25° C

Temperature Stability: $\pm 0.01\%$ (10 ppm) from -30° C to +50° C

Channel Selection: Momentary pushbutton switches, TUNE Up and Down

Compatibility Modes (6) Digital Hybrid Wireless(tm) (400 Series), 100 Series, 200 Series, Mode 3, Mode 6, and IFB

Pilot Tone: 29.997 kHz IFB & 100 MODE, 32.765 kHz 200 MODE, 400 MODE step selected

Modulation: FM, ± 20 kHz deviation IFB & 100 MODE, ± 75 kHz 200 & 400 MODE

Audio Frequency Response: 100 Hz to 8 kHz, ± 1 dB, IFB MODE system response (see Rolloff)

30 Hz to 20 kHz ± 1 dB, 200 & 400 MODE system response (see Rolloff)

Rolloff: Low frequency audio rolloff is Menu selectable for 3 dB down at 35 Hz or 50 Hz.

Signal to Noise Ratio: 90 dB typical ("A" weighted)

Audio Compressor: 2 to 1 IFB, 100, and 200 Mode

Output Impedance: 50 ohms

Audio Input Levels:

- 0 dBu for Line, RTS1 & RTS2
- -10 dBu for Clear Com
- -42 dBu for mic dry inputs (no phantom power)
- ± 50 Vdc max

Audio Input Config: Balanced and Unbalanced, rear panel selectable for Line, Mic, RTS 1, RTS 2, and Clear Comm

Audio Input Impedance: Greater than 2 K balanced, greater than 1 K unbalanced at any gain setting

Gain Control Range: -18 dB to +24 dB (0 dB nominal center), Menu selectable

Audio Input Jack: Standard XLR female connector

Input Power: 12 to 14 VDC typical, 200 ma. max.; Max. Input Range 6 to 18 VDC

Power Input Jack: Coax type, locking LZR RL26AE

Indicators: Backlit Liquid Crystal Display. Displays modulation meter, frequencies, modes, rolloff, audio level, and tuning groups.

Front panel controls:

- MENU momentary pushbutton switch
- Power OFF-TUNE-XMIT, 3 position slide switch
- Select Up momentary pushbutton switch
- Select down momentary pushbutton switch

Rear panel controls: Input Mode Select, 4 section DIP switch

Weight: 9 ozs.

Size: 5.25" L (including connectors) x 3.25" W x 1.25" H

Specifications subject to change without notice.

Emission designator: 180KF3E

